

## COMPARISON OF AN ELECTROMAGNETIC AND OPTICAL SYSTEM DURING DYNAMIC MOTION

Vipul Lugade, Tzurei Chen, Carl Erickson, Masahiro Fujimoto,  
Jun G San Juan, Andy Karduna and Li-Shan Chou\*

*Department of Human Physiology  
University of Oregon  
Eugene, Oregon 97403, USA*

Accepted 10 July 2015

Published 7 September 2015

### ABSTRACT

Few studies have concurrently investigated the accuracy and repeatability of an optical and electromagnetic (EM) system during dynamic motion. The purposes of this study were to: (1) assess the accuracy of both an EM and optical system when compared to a gold standard and (2) to compare the intra- and inter-day repeatability during 3D kinematic motion of both systems. The gold standard used for accuracy assessment was a robot programmed to manipulate a carbon fiber beam through pre-defined motions within the capture volume of both systems at 30, 45 and 60°/s. A total of 12 healthy young adults were tested for intra- and inter-day repeatability of hip, knee and ankle joint angles during a sit-to-stand movement. Marker trajectories were captured using an 8-camera Motion Analysis system and a Polhemus Liberty system. Optical markers for both portions of the study were precisely marked to allow for digitization by the EM system, with collections taken at 120 Hz. Accuracy and repeatability were assessed using the RMS error and coefficient of multiple correlations (CMC), respectively. The optical system demonstrated a 1–2.5° lower RMS error in tracking the robot movements in the transverse and sagittal planes when compared to the EM system. However, it was possible that metal interference affected the accuracy of the EM system. High intra-day and inter-day repeatability was demonstrated by both systems during the sit-to-stand task. The optical system did demonstrate slightly higher CMC values for between day trials, though skin motion artifact might have affected the EM system to a greater extent. Overall, both systems demonstrated an adequate ability to track dynamic motion.

*Keywords:* Validity; Reliability; Motion analysis; Kinematics; Sit-to-stand.

### INTRODUCTION

Biomechanics laboratories often have to choose between electromagnetic (EM) and optical systems when conducting research. While the purpose of both systems is to determine the position and orientation of body segments in a three-dimensional (3D) volume, their methods for capturing data are varied. To date, relatively few studies have provided information on the accuracy and repeatability of these different systems during dynamic motion.

Among optical systems, either passive reflective or active light-transmitting markers can be used with a set of cameras to determine marker trajectories in space.<sup>1</sup> For such systems, accuracy has been shown to be dependent on the calibration field, camera distance from markers, and motion of the markers in the capture volume.<sup>1,2</sup> In order to perform successful data collection, proper calibration and setup, including number and location of cameras, size of measurement volume, precise calibration device and procedure needs to be followed.<sup>3</sup>

---

\*Corresponding author: Li-Shan Chou, Department of Human Physiology, University of Oregon, Eugene, Oregon 97403, USA.  
E-mail: chou@uoregon.edu

For EM systems, a receiver is placed on segments of interest, with positions and orientations tracked when within operating range of a transmitter. Accuracy is dependent on distance between the receiver and transmitter, magnetic interference and number of receivers.<sup>4,5</sup> Similar to optical markers, motion artifact can be of concern among EM systems, though EM systems do allow for accurate real-time tracking without line-of-sight restrictions.<sup>6</sup>

Studies have investigated the performance of optical systems,<sup>3,7,8</sup> and EM systems,<sup>9,10</sup> though comparison of the validity and reliability of optical and EM systems are lacking. Hassan and colleagues found that both systems were appropriate for measuring upper extremity kinematics and deviations occurred mostly at smaller angles.<sup>5</sup> Their study showed that optical systems were clinically comparable to EM systems for accuracy of kinematic data only when appropriate *post hoc* algorithms were applied. However, repeatability of the data for the systems was not assessed. To our knowledge, there are no studies investigating the repeatability of both optical and EM systems.

The goal of this study was to quantify measurement error for an EM and optical system. In order to achieve this aim, we had two main purposes: (1) To assess the accuracy of both an EM and optical system when compared to our gold standard during dynamic motions and (2) To measure and compare the intra- and inter-day repeatability of 3D kinematic motion of both systems. The gold standard used for accuracy assessment was a six-degree of freedom robot programmed to manipulate a carbon fiber beam through pre-defined motions within the capture volume of both the EM and optical systems. Hip, knee and ankle joint angles during a sit-to-stand movement were measured to assess repeatability.

## MATERIALS AND METHODS

### Assessment of Accuracy

Dynamic assessment of accuracy for both systems was performed using a LR Mate 200iB six-degree of freedom robot (FANUC Robotics America Inc., Rochester Hills, MI). The robot manipulated a rigid carbon fiber beam attached to the most distal segment [Fig. 1(A)]. The carbon fiber beam, which has high strength and a low mass, was moved through a range of  $-20^\circ$  to  $70^\circ$  in the sagittal plane at each  $15^\circ$  increment in the transverse plane between  $-45^\circ$  to  $45^\circ$  (Fig. 2). Movement was selected to simulate shoulder flexion/extension at different scapular plane angles, while keeping the EM receiver within range of the transmitter. The robot moved

through this known range of motion at three different speeds:  $30^\circ/s$ ,  $45^\circ/s$  and  $60^\circ/s$ .

Three non-co-linear reflective optical markers were placed on the carbon fiber beam, with an additional three markers placed on a rigid surface, to be used as the reference for kinematics analysis [Fig. 1(B)]. Each optical marker was precisely marked at four points to allow for digitization by the EM system. Two EM receivers were placed on the rigid beam and surface, with digitized marker locations tracked during all trials. Prior to all data collection both systems were calibrated by experienced investigators. Marker trajectories were captured simultaneously by an EM (Liberty electromagnetic tracker, Polhemus Inc., Burlington, VT) and an optical system (8-camera Eagle System, Motion Analysis Corp., Santa Rosa, CA), each with a sampling rate of 120 Hz. Both systems were triggered and synchronized with the robot using a laptop which was controlling the robot. Additionally, joint movements of the robot were tracked at 12.5 Hz. Tracking from both systems data were synchronized to the robot and re-sampled to 12.5 Hz in order to determine the RMS error.

All data were filtered using a 4th order lowpass zero-lag Butterworth filter with a 6 Hz cutoff frequency. Comparisons were further performed versus non-filtered data and smoothing standards used by Hassan and colleagues.<sup>5</sup> Angles in the sagittal and transverse plane were calculated using a Y-X-Z Euler sequence, with Y representing the superior-inferior axis, X the anterior-posterior axis and Z the mediolateral axis. The accuracy of each system to the gold standard was assessed for the angles calculated and distances between two markers using the RMS error throughout the trial. Differences in beam marker distances were compared to a resting condition, where marker position data was collected with the beam placed at  $0^\circ$  in both the transverse and sagittal planes under no dynamic movement.

The effect of robot metal interference on the EM system was tested with the use of precisely positioned EM receivers placed on a flat ceramic surface. Distance between the EM transmitter and robot was varied between 40 and 130 cm, with angular error and position error of the markers recorded at each distance. Errors in angle and position due to metallic interference were reported in  $^\circ$  and cm, respectively.

### Assessment of Repeatability

A total of 12 young healthy adults (6 female, mean age =  $25.6 \pm 5.3$  years) were recruited for this part of the study. The 3D trajectories of 15 reflective optical markers placed at bony landmarks were captured by the

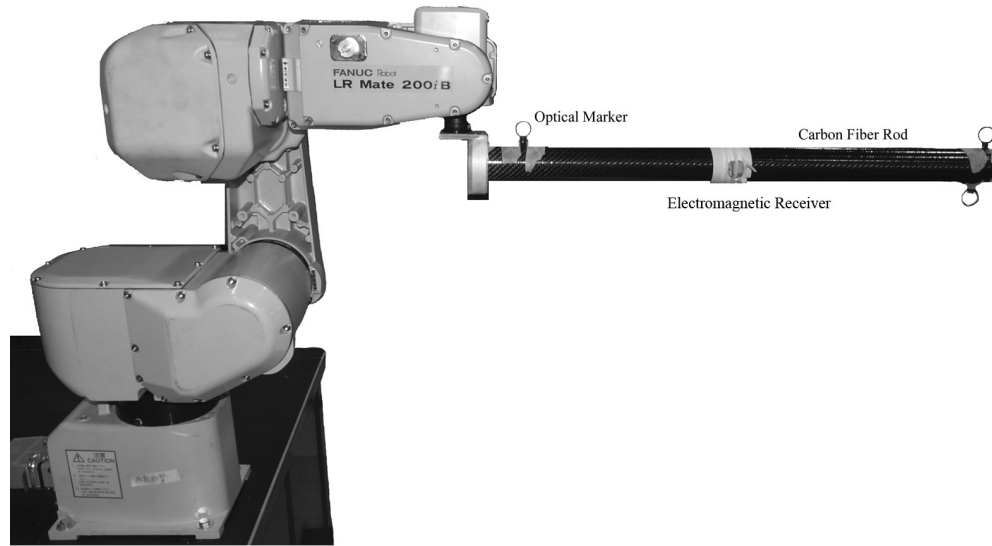

(A)

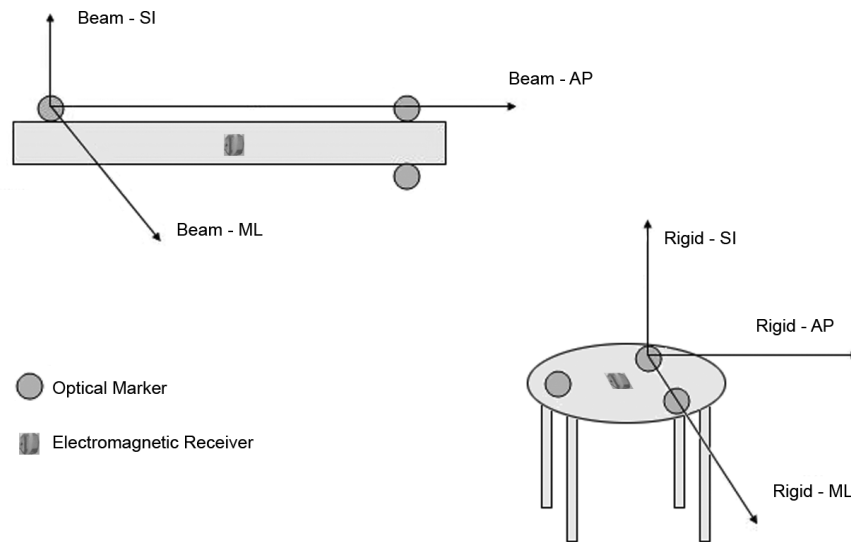

(B)

**Fig. 1** Setup of the robot during data collection (A), with three non co-linear optical markers placed on both a carbon fiber beam and rigid surface. Markers defined orthogonal axes in the anterior-posterior (AP), medial-lateral (ML) and superior-inferior (SI) directions (B). All optical markers were also digitized for use by the EM system with an EM receiver placed on the beam and surface.

optical system.<sup>11</sup> The 15 optical markers were precisely marked at four points to allow for digitization for the EM system. Seven EM receivers were attached to the following locations: the spinous process of the 5th lumbar vertebra, the lateral aspect of the right and left thigh, the lateral aspect of the right and left shank, and the top of the right and left foot (metatarsal bones).

Participants were instructed to perform a sit-to-stand task from a 46 cm high chair at a self-selected natural speed. They were asked to sit on a chair with the

trunk vertical, and self-selected comfortable feet placement. Several practice trials were performed to find their comfortable starting position. The participants folded their arms on the chest throughout the task. Three trials were collected for each participant. After 15 min of rest, additional three trials were collected. Participants were asked to repeat the same protocol on the following day, with three sit-to-stand trials.

Sagittal plane hip, knee and ankle joint angles during all trials were calculated using a laboratory written

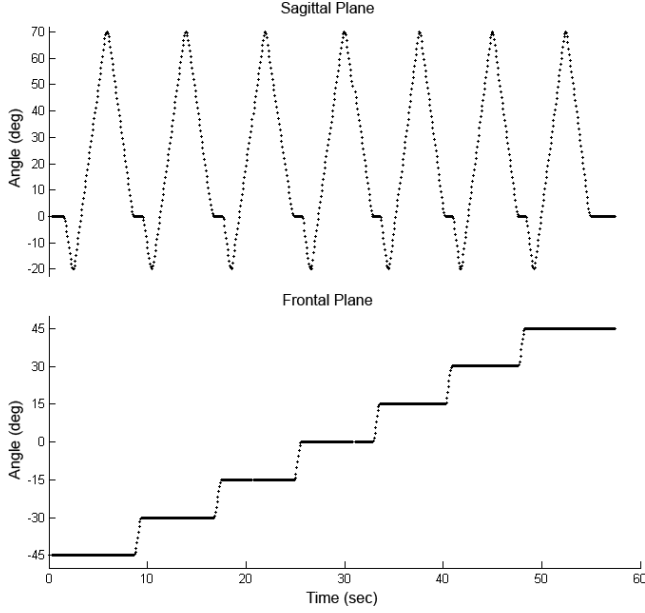

**Fig. 2** Motions in the sagittal and transverse plane prescribed to the robot during testing sessions at 30°/s.

Matlab program (MATLAB 7.0; The Mathworks Inc., Natick, MA) from data collected by both systems. The sit-to-stand motion began at the first discernible hip flexion of more than 0.025° between consecutive frames. The end of the motion was defined when consecutive frames of hip flexion did not exceed a difference of 0.025°. <sup>12</sup> For further analysis, all data were interpolated to 101 data points, which represented 0–100% of the sit-to-stand movement. Coefficient of multiple correlation (CMC) was used to assess intra-day and inter-day repeatability of the movement.

CMC for intra-day repeatability was given by:

$$\text{CMC} = \sqrt{1 - \frac{\sum_{i=1}^M \sum_{j=1}^N \sum_{t=1}^T (Y_{ijt} - \bar{Y}_{it})^2 / MT(N-1)}{\sum_{i=1}^M \sum_{j=1}^N \sum_{t=1}^T (Y_{ijt} - \bar{Y}_i)^2 / M(NT-1)}}, \quad (1)$$

where  $i$  represents the test day,  $j$  the trial number and  $t$  the time point, <sup>13</sup>  $\bar{Y}_{it}$  and  $\bar{Y}_i$  are the average at time point  $t$  on the  $i$ th day and the overall mean on the  $i$ th day, respectively. For intra-day repeatability,  $M$  was 1 day,  $N$  was 6 trials, and  $T$  was 101 data points.

Inter-day repeatability was assessed using:

$$\text{CMC} = \sqrt{1 - \frac{\sum_{i=1}^M \sum_{j=1}^N \sum_{t=1}^T (Y_{ijt} - \bar{Y}_t)^2 / T(MN-1)}{\sum_{i=1}^M \sum_{j=1}^N \sum_{t=1}^T (Y_{ijt} - \bar{Y})^2 / (MNT-1)}}, \quad (2)$$

where  $\bar{Y}_t$  and  $\bar{Y}$  are the average at time point  $t$  over  $NM$  gait cycles and  $Y$  is the overall mean divided by time,

respectively. <sup>13</sup> For inter-day repeatability,  $M$  was 2 days,  $N$  was 3 trials and  $T$  was 101 data points. Similar waveforms will return CMC values close to 1, while dissimilar waveforms will tend to 0. Both intra-day and inter-day repeatability were calculated for the hip, knee and ankle joint angles. A paired  $t$ -test was used to determine differences in the CMCs between the optical and EM system (SPSS 20.0; IBM Corp., Armonk, NY). The significance was set at an alpha level of 0.05.

## RESULTS

### Accuracy

During metal interference tests, the EM system demonstrated similar position errors at all distances from the robot (Table 1). Increasing angular error was demonstrated as the EM transmitter moved within 66 cm of the robot. Therefore, the EM transmitter was placed at least 75 cm from the robot for all subsequent trials. Sagittal plane angles [Fig. 3(A)] and transverse plane angles [Fig. 3(C)] demonstrated that both systems tracked the motion of the robot. When compared to the robot, the optical system showed consistent differences across time. However, the EM system demonstrated an inverted U pattern in the sagittal plane, with the greatest difference found when the beam was between  $-15$  and  $15^\circ$  in the transverse plane [Fig. 3(B)]. The differences in the transverse plane for the EM system deviated from the gold standard during the entire trial [Fig. 3(D)].

The optical system demonstrated a small increase in the sagittal plane RMS error and decrease in the transverse plane RMS with increasing speed (Table 2). Similar patterns were demonstrated by the EM system apart from increased transverse plane RMS error at 60°/s, when compared to lower speeds. The EM system had approximately 2.5° greater RMS error than the optical system at all speeds in the sagittal plane. In the transverse plane, the calculated RMS error of the EM system was approximately 1–2° greater than the optical

**Table 1.** RMS Error in the EM System Based on Distance from the Transmitter to the Robot.

| Distance (cm) | Angular Error (°) | Position Error (cm) |
|---------------|-------------------|---------------------|
| 130.8         | 0.0068            | 0.012               |
| 118.1         | 0.0075            | 0.011               |
| 105.4         | 0.0065            | 0.010               |
| 92.7          | 0.0052            | 0.0018              |
| 81.3          | 0.0065            | 0.073               |
| 66.0          | 0.012             | 0.0031              |
| 52.1          | 0.027             | 0.013               |
| 40.6          | 0.060             | 0.019               |

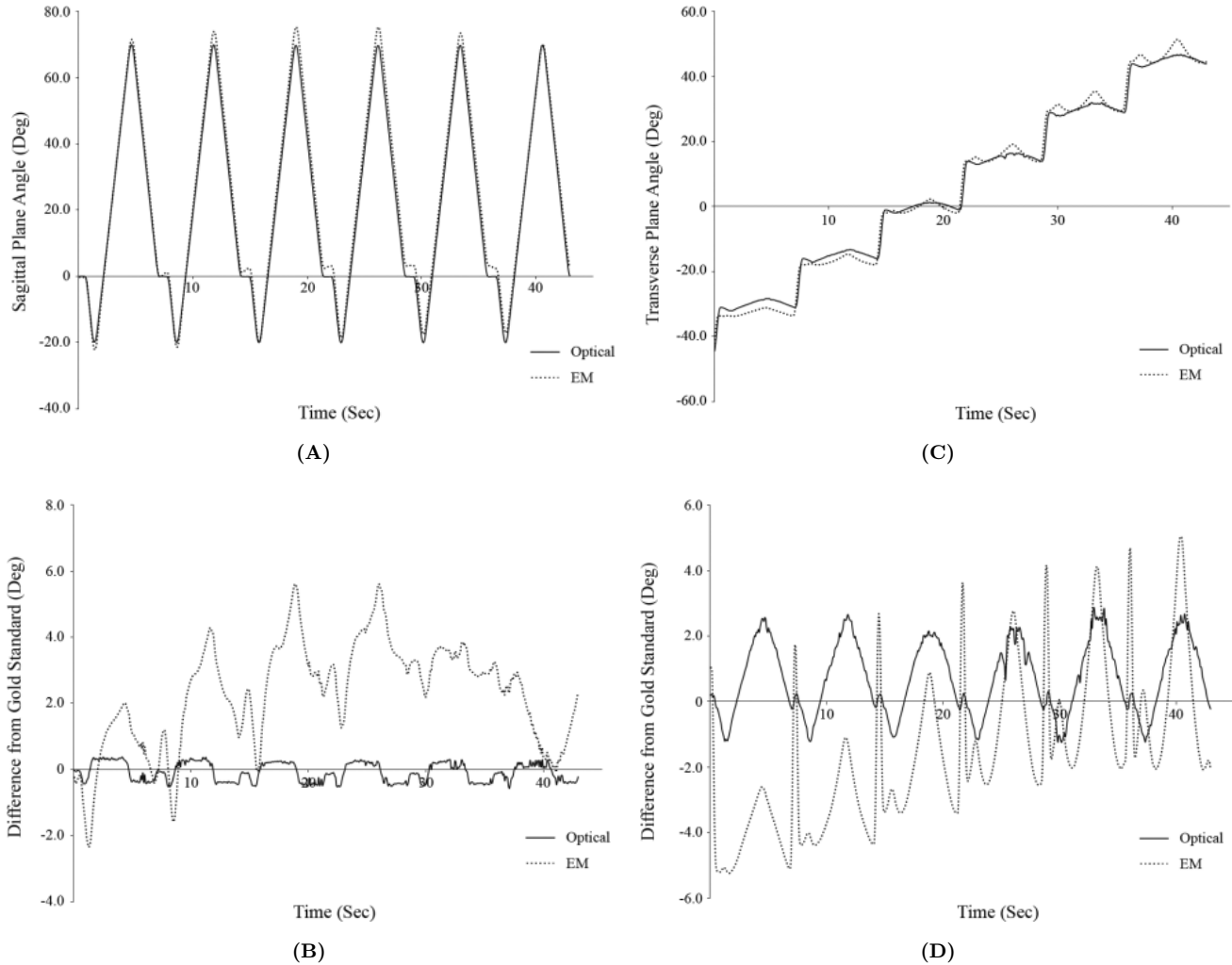

**Fig. 3** Sagittal (A) and transverse (C) plane motion as predicted by the optical and EM systems at 30°/s. In addition, the difference from the gold standard in both the sagittal (B) and transverse (D) plane was calculated for both the optical and EM systems. Similar patterns were demonstrated at 45°/s and 60°/s.

system. Slight differences in the sagittal plane and transverse plane RMS values were demonstrated by both the optical and EM system when smoothing was performed.

Conversely, the optical system demonstrated greater RMS error in tracking distances between two markers on the same rigid body when compared to the EM system (Table 3). RMS errors for the optical system when

**Table 2.** RMS Error (in °) for the Optical and EM Systems when Compared to the Gold Standard.

| Joint Angle (°)  |                        | 30°/s   |       | 45°/s   |       | 60°/s   |       |
|------------------|------------------------|---------|-------|---------|-------|---------|-------|
|                  |                        | Optical | EM    | Optical | EM    | Optical | EM    |
| Sagittal Plane   | No Smoothing           | 0.235   | 2.731 | 0.267   | 2.896 | 0.253   | 2.971 |
|                  | Smoothing <sup>a</sup> | 0.235   | 2.731 | 0.273   | 2.899 | 0.250   | 2.969 |
|                  | Smoothing <sup>b</sup> | 0.230   | 2.920 | 0.269   | 3.028 | 0.245   | 2.934 |
| Transverse Plane | No Smoothing           | 1.417   | 2.607 | 1.313   | 2.485 | 1.309   | 3.462 |
|                  | Smoothing <sup>a</sup> | 1.407   | 2.608 | 1.288   | 2.481 | 1.291   | 3.462 |
|                  | Smoothing <sup>c</sup> | 1.385   | 2.605 | 1.259   | 2.327 | 1.244   | 2.946 |

<sup>a</sup>Data filtered using a zero-lag 4th order Butterworth filter, with a 6 Hz cutoff frequency.

<sup>b</sup>Data filtered using a zero-lag 2nd order Butterworth filter, with a 4 Hz cutoff frequency.<sup>5</sup>

<sup>c</sup>Data filtered using a zero-lag 2nd order Butterworth filter, with a 1.5 Hz cutoff frequency.<sup>5</sup>

**Table 3.** RMS Error in Marker Distances (in mm) for the Optical and EM Systems Compared to Resting Conditions.

| Marker Distance (mm) | 30°/s   |       | 45°/s   |       | 60°/s   |       |
|----------------------|---------|-------|---------|-------|---------|-------|
|                      | Optical | EM    | Optical | EM    | Optical | EM    |
| Rigid Beam           | 0.526   | 0.004 | 0.526   | 0.004 | 0.505   | 0.004 |
| Rigid Surface        | 0.130   | 0.002 | 0.160   | 0.003 | 0.147   | 0.006 |

**Table 4.** CMC for the Hip, Knee and Ankle During a Sit-to-Stand [Mean (SD)].

| Joint Angle (°) | Intra-Day (CMC)  |                  |                 | Inter-Day (CMC)  |                  |                 |
|-----------------|------------------|------------------|-----------------|------------------|------------------|-----------------|
|                 | EM               | Optical          | <i>p</i> -Value | EM               | Optical          | <i>p</i> -Value |
| Hip             | 0.974<br>(0.037) | 0.993<br>(0.001) | 0.020           | 0.966<br>(0.016) | 0.980<br>(0.012) | 0.003           |
| Knee            | 0.971<br>(0.071) | 0.995<br>(0.002) | 0.113           | 0.982<br>(0.010) | 0.986<br>(0.008) | 0.087           |
| Ankle           | 0.986<br>(0.044) | 0.998<br>(0.001) | 0.177           | 0.885<br>(0.090) | 0.935<br>(0.055) | 0.030           |

tracking markers on the moving rigid beam and the static rigid surface were approximately 0.5 and 0.15 mm for each speed, respectively. The EM system demonstrated approximately 0.004 mm RMS errors for marker distances on both the static and moving rigid segments.

## Repeatability

Mean ranges of the hip, knee and ankle joint angles during sit-to-stand movement were  $82.3 \pm 10.2$ ,  $87.3 \pm 10.3$  and  $17.6 \pm 12.0^\circ$ , respectively, for the optical system and  $83.9 \pm 12.3$ ,  $87.0 \pm 11.5$  and  $15.9 \pm 13.3^\circ$ , respectively, for the EM system. For both the EM and optical systems, the repeatability of joint angular motion at the hip, knee, and ankle were high, with an average CMC value of 0.971, for both inter-day and intra-day (Table 4). Furthermore, the optical system demonstrated significantly higher intra-day and inter-day CMCs than the EM system at the hip joint. For the ankle joint, the inter-day CMC of the optical system was significantly greater than the EM system, but not the intra-day CMC.

## DISCUSSION

### Accuracy

The first purpose of this study was to assess the accuracy of the optical and EM system during dynamic motion. Although the EM system demonstrated greater accuracy in determining the distances between two points on a rigid segment, the EM system also demonstrated greater RMS error in calculating angles between

two segments in both planes, when compared to the optical system. The accuracy of the EM system may have been affected by metal interference and the distance between the sensors and the receiver, though metal objects such as force plates were removed from the immediate vicinity. The majority of the motion of the rigid beam was confined to the center of the capture volume of both the optical system and EM system. Movement to the end ranges of motion might have contributed to the greater error for the EM system at those points, though the hemisphere of accuracy for the Polhemus system is stated to have approximately a 1.5 m radius. All collections were performed on a single day with calibration, marker placement and digitization procedures performed for the optical and EM systems by experienced investigators. While the robot was maintained at distances longer than 75 cm away from the EM transmitter, it is possible that the metal interference of the robot and from the gait laboratory created greater error in EM system angles than in the optical system. Chosen positions were considered appropriate due to the smaller angular errors seen at distances greater than 40 cm (Table 1). It is also possible that movement interference onto the receivers during the experiment, or even the choice of Euler angle sequences, affected the angular RMS values.

The EM system did demonstrate greater RMS accuracy when measuring distances between markers. Since these distances are calculated based on the position of digitized points in relation to the EM receiver, it is expected that this value will remain consistent throughout the movement. In addition, the RMS values obtained for the optical system are in agreement with



those found previously.<sup>7</sup> In Richards' study, the motion system demonstrated 0.059 cm RMS error for two markers spaced at 50 cm apart, with a maximum error of 0.183 cm.

Differences from the gold standard were most prevalent at end ranges of motion in the sagittal plane and at 0° in the transverse plane [Figs. 3(B) and 3(D)]. Along with possible crosstalk between the sagittal and transverse planes,<sup>14</sup> it is possible that collecting data at greater than 120 Hz might have provided us with a more refined profile at the end ranges of motion and possibly reduced the RMS errors for both systems. The difference in sampling frequency between the optical/EM systems and the robot also could have affected errors among both motion systems. Interpolation was performed in order to access the RMS error, and imperfect synchronization between systems might have induced a systematic error, as seen for the optical system [Figs. 3(B) and 3(D)]. When the robot approached 0° in the transverse plane, it was closer to the EM transmitter, which might have generated greater error [Fig. 3(B)]. Additionally, as the robot approached 45° in the transverse plane, the receivers were furthest away from the transmitter, which might have added additional error.

## Repeatability

CMC values for the optical and EM systems approached 1 for both intra-day and inter-day repeatability. Slightly reduced inter-day ankle CMC values of approximately 0.9 were due to non-controlled participants' feet placement between trials or between days. During a sit-to-stand motion, foot position has been shown to influence movement time, hip flexion angles and speeds as well as modifying the joint moments and ground reaction forces.<sup>15</sup> With a posterior or anterior placement of the feet, ankle angles would have changed as well. Participants performed their self-selected sit-to-stand motion, and while this was a limitation of the study, it ensured that additional constraints were not placed on the subject during their movement task. Additionally, the patterns of the hip, knee, ankle joint curves during the sit-to-stand motion were similar to those reported previously.<sup>16</sup>

A well-trained investigator familiar with the optical system placed markers on both testing days. Similarly, an experienced researcher familiar with the EM system performed digitization of these optical markers on both testing days. The participants performed the sit-to-stand motion in the center of the capture volume for the optical and EM systems. The optical system is accommodated to conduct gait analysis, with a capture volume of 5 m long,

2 m wide and 3 m high. Accuracy and repeatability of marker tracking might have improved with a capture volume optimized to a sit-to-stand motion.

Marker placement, digitization differences, inherent physiological variability in performing the sit-to-stand motion, and skin motion artifact could have affected the results for both systems. Smaller inter-day repeatability within the EM system might be due to thigh and shank receiver placement and motion artifact. Along the thigh, there is an abundance of soft tissue, and placement of this receiver on the assumed rigid body was a limitation of the study. However, all attempts were made to place both this receiver and the shank receiver along a bony aspect of the segment. Skin motion artifacts during scapular motion using the same EM system were shown to have reasonable RMS errors when compared to bone pins.<sup>17</sup> No studies to our knowledge have assessed the skin motion of the lower extremity using an EM system. Prior studies have investigated methods for compensating for skin motion artifact by utilizing point clusters and an over-abundance of markers to reduce effects from skin deformation.<sup>18</sup> However, this approach can be time consuming and increase neurosensory stimulus for the patient, resulting in non-normal movement.<sup>19</sup> Along with the placement of a single EM receiver versus multiple optical markers resulting in varied skin motion deviations and patient stimulus when comparing the two systems, it is speculated that a heavier, wired EM receiver might lead to greater error as well,<sup>5</sup> though in our study both systems demonstrated high CMC values.

## CONCLUSIONS

Both the EM and optical systems demonstrated an ability to adequately track dynamic motion of a robot and the sit-to-stand motion of young adults within and between days. While the EM system might have demonstrated greater errors due to metal interference in the room and lower repeatability due to skin motion artifact of the sensors, it still performed adequately when compared to the optical system. Further work might investigate the accuracy and repeatability of both systems during dynamic motion *in vivo*, utilizing other techniques for a gold standard such as bone pins.

## Acknowledgment

The authors would like to thank Sue Ewers, Robert Catena, Tal Amasay and Lucas Ettinger for their assistance during data collections.

## REFERENCES

1. Maletsky LP, Sun J, Morton NA, Accuracy of an optical active-marker system to track the relative motion of rigid bodies, *J Biomech* **40**:682, 2007.
2. Dabnichki P, Lauder M, Aritan S, Tsirakos D, Accuracy evaluation of an on-line kinematic system via dynamic tests, *J Med Eng Technol* **21**:53, 1997.
3. Chiari L, Della Croce U, Leardini A, Cappozzo A, Human movement analysis using stereophotogrammetry. Part 2: Instrumental errors, *Gait Posture* **21**:197, 2005.
4. Bull A, Berkshire F, Amis A, Accuracy of an electromagnetic measurement device and application to the measurement and description of knee joint motion, *P I Mech Eng H* **212**:347, 1998.
5. Hassan EA, Jenkyn TR, Dunning CE, Direct comparison of kinematic data collected using an electromagnetic tracking system versus a digital optical system, *J Biomech* **40**:930, 2007.
6. Franz AM, Haidegger T, Birkfellner W, Cleary K, Peters TM, Maier-Hein L, Electromagnetic tracking in medicine — A review of technology, validation and applications, *IEEE Trans Med Imaging* **33**:1702, 2014.
7. Richards J, The measurement of human motion: A comparison of commercially available systems, *Hum Movement Sci* **18**:589, 1999.
8. Chu Y, Akins J, Lovalekar M, Tashman S, Lephart S, Sell T, Validation of a video-based motion analysis technique in 3-D dynamic scapular kinematic measurements, *J Biomech* **45**:2462, 2012.
9. McQuade K, Finley M, Harris-Love M, McCombe-Waller S, Dynamic error analysis of ascension's flock electromagnetic tracking device using a pendulum model, *J Appl Biomech* **18**:2002.
10. Frantz DD, Wiles A, Leis S, Kirsch S, Accuracy assessment protocols for electromagnetic tracking systems, *Phys Med Biol* **48**:2241, 2003.
11. Hahn ME, Chou LS, Age-related reduction in sagittal plane center of mass motion during obstacle crossing, *J Biomech* **37**:837, 2004.
12. Millington PJ, Myklebust BM, Shambes GM, Biomechanical analysis of the sit-to-stand motion in elderly persons, *Arch Phys Med Rehabil* **73**:609, 1992.
13. Kadaba MP, Ramakrishnan HK, Wootten ME, Gainey J, Gorton G, Cochran GV, Repeatability of kinematic, kinetic, and electromyographic data in normal adult gait, *J Orthop Res* **7**:849, 1989.
14. Kadaba MP, Ramakrishnan H, Wootten M, Measurement of lower extremity kinematics during level walking, *J Orthop Res* **8**:383, 1990.
15. Janssen WG, Bussmann HB, Stam HJ, Determinants of the sit-to-stand movement: A review, *Phys Ther* **82**:866, 2002.
16. Kralj A, Jaeger RJ, Muni M, Analysis of standing up and sitting down in humans: Definitions and normative data presentation, *J Biomech* **23**:1123, 1990.
17. Karduna AR, McClure PW, Michener LA, Sennett B, Dynamic measurements of three-dimensional scapular kinematics: A validation study, *J Biomech Eng* **123**:184, 2001.
18. Andriacchi T, Alexander E, Toney M, Dyrby C, Sum J, A point cluster method for *in vivo* motion analysis: Applied to a study of knee kinematics, *J Biomech Eng* **120**:743, 1998.
19. Mündermann L, Corazza S, Andriacchi TP, The evolution of methods for the capture of human movement leading to markerless motion capture for biomechanical applications, *J Neuroeng Rehabil* **3**:6, 2006.